



Parts and Accessories Installation Instructions

Aerial Amplifier Retrofit BMW 5 Series Saloon (E39) BMW 5 Series Touring (E39/2)

These installation instructions only apply to cars fitted with the Bluetooth universal BMW hands-free device

Important information

Subject to technical modifications.

Target group

These installation instructions are primarily designed for use within the BMW dealership organisation and by authorised BMW service companies. In any event the target group for these installation instructions is specialist personnel trained on BMW cars with the appropriate specialist knowledge.

All work must be completed using the latest BMW repair manuals, circuit diagrams, servicing manuals and work instructions in a rational order using the prescribed tools (special tools) and observing current health and safety regulations.

Installation information

Ensure that the cables/lines are not kinked or damaged as you install them in the car.

The installed cables are to be secured with cable ties.

Installation time

Approx. 0.5 hours, but this may vary depending on the condition of the car and the equipment in it.

Retrofit kit No.

84 64 0 301 720

See EPC for other retrofit kit part numbers.

List of special equipment

The following special equipment must be taken into consideration when installing the retrofit kit:

SA 609 Navigation system

Special tools required

None

Contents

Section	Page
1. Preparations.....	3
2. Parts list	4
3. To install and connect the aerial amplifier (E39 without SA 609 only).....	5
4. To install and connect the aerial amplifier (E39 with SA 609 only).....	6
5. To install and connect the aerial amplifier (E39/2 only)	7
6. Concluding work	8

1. Preparations

	TIS instruction No.
Conduct a brief test	---
Disconnect the negative pole of the battery	12 00 ...
The following components must be removed first of all:	
Boot trim panel at left (E39 only)	---
Charger/hands-free electronic control unit (E39/2 only)	---
Boot floor trim at front (E39/2 only)	51 47 131

2. Parts list

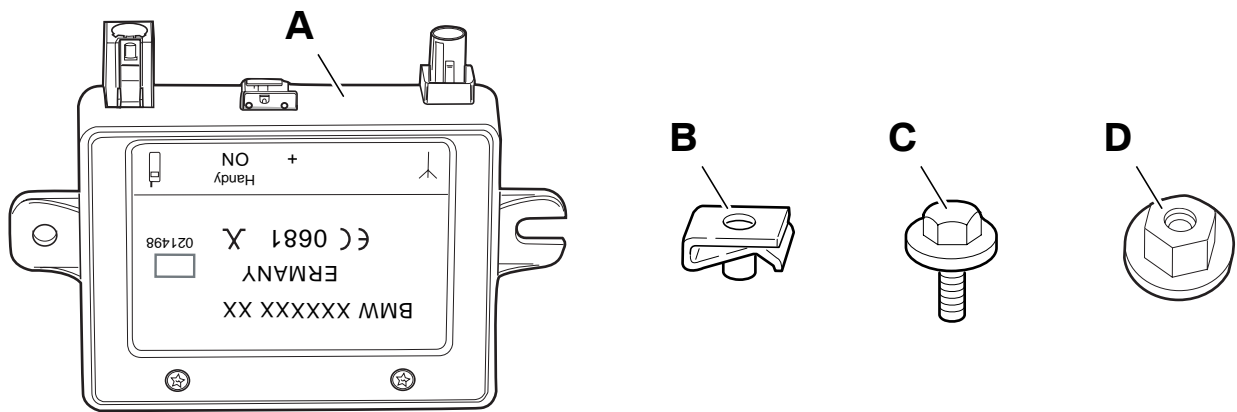

046 1226 Z

Legend

- A** Aerial booster
- B** Speed nut M5
- C** Hexagonal screw M5 x 14
- D** Hexagonal nut M5 (2x)

3. To install and connect the aerial amplifier (E39 without SA 609 only)

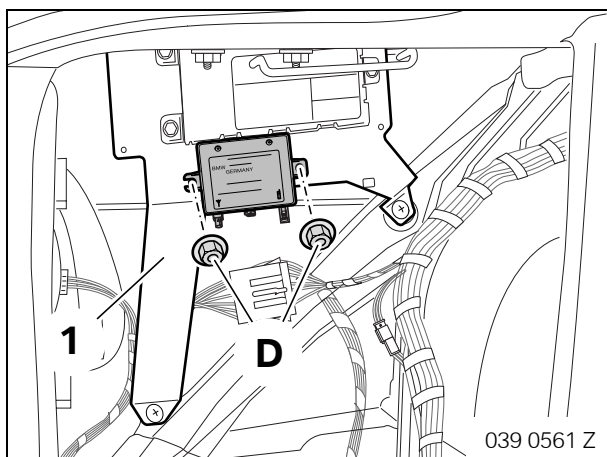

Use hexagonal nuts **D** to screw aerial amplifier **A** onto the universal charger/hands-free electronic control unit holder (1).

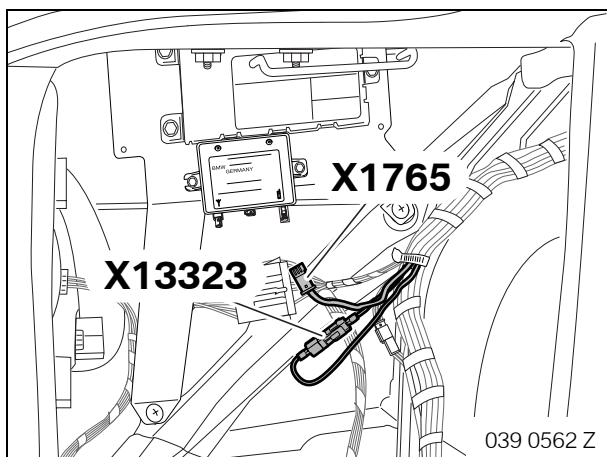

Open Fakra plug connector **X13323**.

Release tied back, black 3-pin plug **X1765** from the wiring harness.

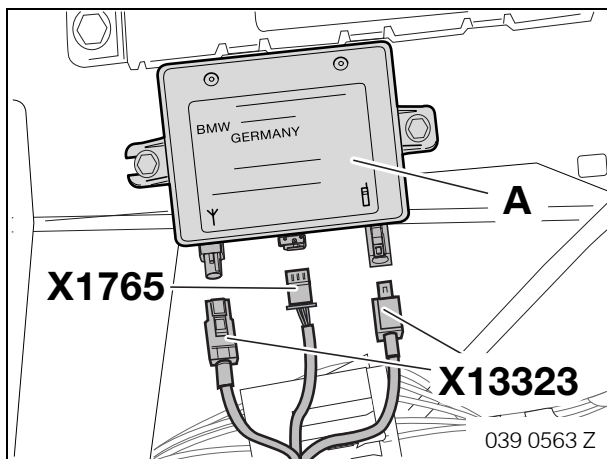

Connect plug **X1765** and Fakra socket and plug contact **X13323** to aerial amplifier **A**.

4. To install and connect the aerial amplifier (E39 with SA 609 only)

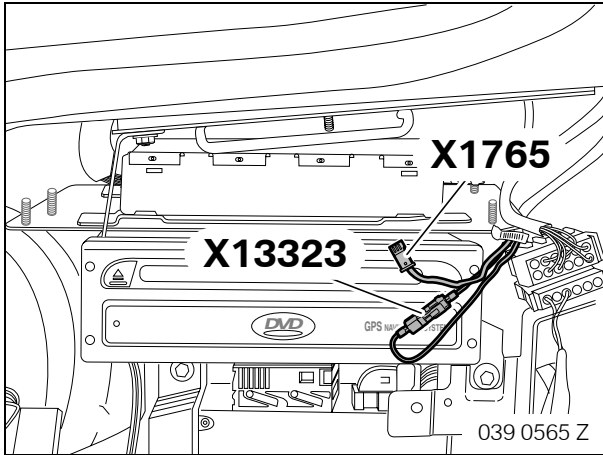

Open Fakra plug connector **X13323**.

Release tied back, black 3-pin plug **X1765** from the wiring harness.

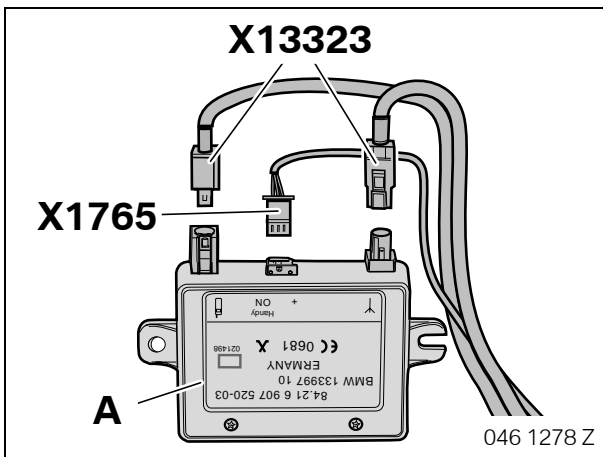

Connect plug **X1765** and Fakra socket and plug contact **X13323** to aerial amplifier **A**.

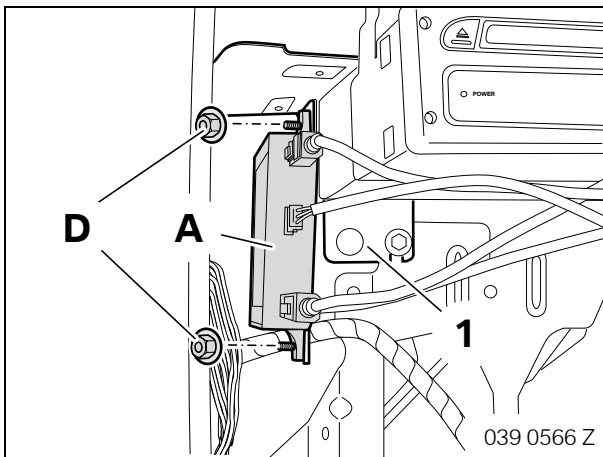

Use hexagonal nuts **D** to screw aerial amplifier **A** onto the module holder (1).

5. To install and connect the aerial amplifier (E39/2 only)

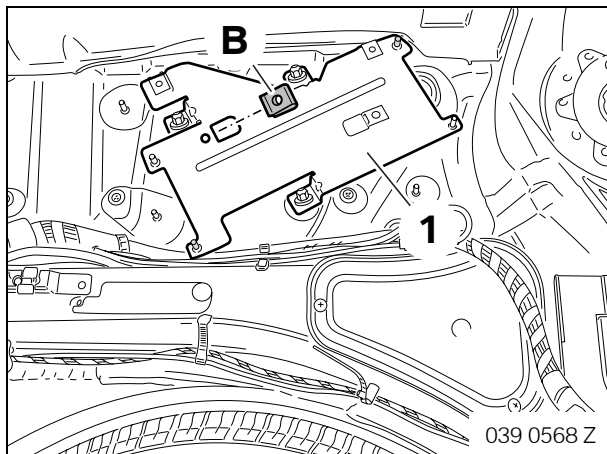

Place speed nuts **B** on the universal charger/hands-free electronic control unit holder (1).

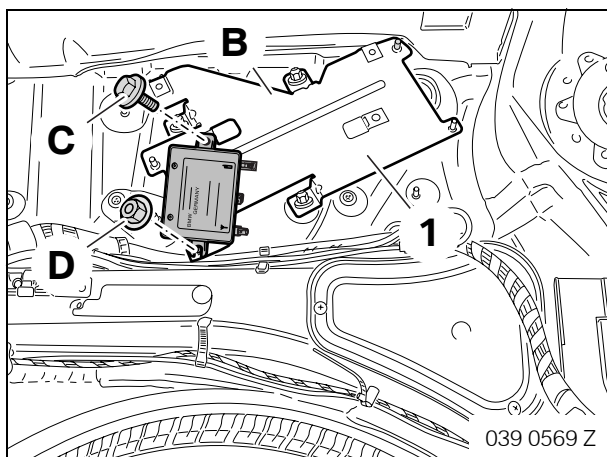

Use hexagonal screw **C** and hexagonal nut **D** to screw aerial amplifier **A** onto the universal charger/hands-free electronic control unit holder (1).

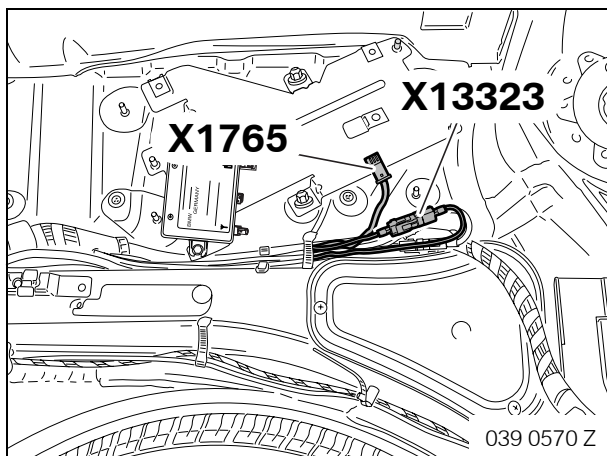

Open Fakra plug connector **X13323**.

Release tied back, black 3-pin plug **X1765** from the wiring harness.

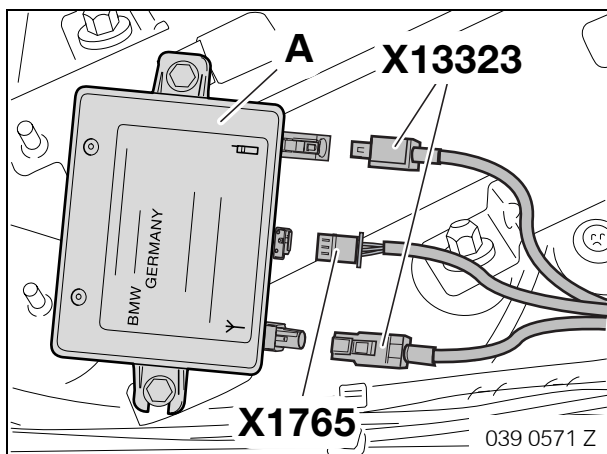

Connect plug **X1765** and Fakra socket and plug contact **X13323** to aerial amplifier **A**.

6. Concluding work

This retrofit system does not require coding.

- Connect battery
- Conduct a brief test with DIS/MoDiC/GT 1
- Conduct a function test
- Assemble the car again following the instructions to dismantle it in reverse order