

Original
BMW Zubehör



Bedienungsanleitung

Freude am Fahren

Bluetooth Anmeldung Motorola V3

Bluetooth registration Motorola V3

Référencement Bluetooth Motorola V3

Bluetooth aanmelding Motorola V3

Bluetooth-anslutning Motorola V3

Collegamento Bluetooth Motorola V3

Registro Bluetooth de Motorola V3

Sistema Bluetooth de registo dos telemóveis Motorola V3



Mehr über BMW

www.bmw.de
www.bmw.com



Freude am Fahren

Bluetooth registration Motorola V3 Operating instructions

Contents

EN

General information	18
Information on operation	19
Information on registration	19
Insert the mobile phone in the Original BMW Snap-In adapter	20
Remove the mobile phone from the Original BMW Snap-In adapter	21
Registration of the mobile phone for cars without iDrive	22
1 Series	
3 Series Saloon built after 12/04	
3 Series Touring built after 09/05	
3 Series Coupé built after 08/06	
Registration of the mobile phone for cars with iDrive	24
1 Series	
3 Series Saloon built after 12/04	
3 Series Touring built after 09/05	
3 Series Coupé built after 08/06	
5 Series Saloon built after 03/03	
5 Series Touring built after 03/04	
6 Series Coupé	
6 Series Convertible	
Registration of the mobile phone for 7 Series cars built after 09/05	27

General information

BMW recommends to use only parts and accessories that have been tested and approved by BMW in terms of their safety, function and suitability.

Symbols used



Denotes instructions or warnings that you must observe.



Denotes instructions that draw your attention to special features.



Denotes measures designed to protect the environment.



Denotes a movement that must be completed in the direction indicated by the arrow.

◀ Denotes the end of the instruction.

Bluetooth technology in general



The use of Bluetooth technology is not allowed in some countries. Contact your BMW service to ask in which countries this is the case. Mobile phones may not be paired in these countries. ◀

Bluetooth technology makes wireless communication between your mobile phone and your car possible. Data and speech are transferred over short distances via radio link. A cable connection is not required.

In order to use Bluetooth technology, your mobile phone must support this technology and first be registered to your car.

Bluetooth technology in your car

Once registered, the connection process between your mobile phone and your car is automatic or manual.

This process can take up to 30 seconds.



The automatic or manual connection process depends on your mobile phone's individual settings. ◀

Once your mobile phone is paired, it is automatically detected as soon as it is in the interior of the car if the engine is running or the ignition has been switched on.

You can pair up to four mobile phones. If you pair a fifth mobile phone, the one which was registered first will be deleted.

If several mobile phones are detected at the same time, only the phone last selected can connect with your car.

If the paired mobile phone has connected, you can operate it using the control elements of your car.

Service information

If the Bluetooth control module hands-free upgrade kit is replaced as part of service work, the mobile phone must be re-registered.

Information on operation

Information on phone operation

BMW recommends that you use the Original BMW Snap-In adapter in phone operation. The Original BMW Snap-In adapter ensures that the battery charges and that the network connection via the external aerial is optimized. If not used, poor reception may occur when using the phone and interference when using the hands-free kit.

Only by using the Original BMW Snap-In adapter is the electromagnetic field strength not higher than during the normal use of the mobile phone outside the car.

Do not operate a mobile phone that has been detected by the car using the phone's keypad since otherwise malfunctions may occur.

Motorola V3 mobile phone in Bluetooth operation

The Motorola V3 mobile phone does not have a connection for an external aerial. This mobile phone connects to the car's external aerial using a wireless connecting aerial integrated in the Snap-In adapter.

Information on registration

Information on phone registration

You need to pair your mobile phone with your car only once.

 Do not make any settings unless the car is at a standstill. ◀

A Bluetooth access code called a passkey is required to register your phone. Depending on the car, this is either a fixed 4-digit or an arbitrary 1-16-digit code.

The 4-digit fixed passkey can be taken from the code card included with your car's documents.

These operating instructions describe the mobile phone with its default settings. The menus for the pairing operation may be changed by personal settings. For further information please refer to the owner's manual supplied with your mobile phone.

 When registering your phone, you are prompted by your mobile phone and/or car to confirm or enter the registration.

The type and sequence of displays or prompts may vary depending on your mobile phone's or car's software version.

In other words, the input sequence of the passkey in your mobile phone and car may vary.

Please note the respective prompts and follow the menu. ◀

Insert the mobile phone in the Original BMW Snap-In adapter

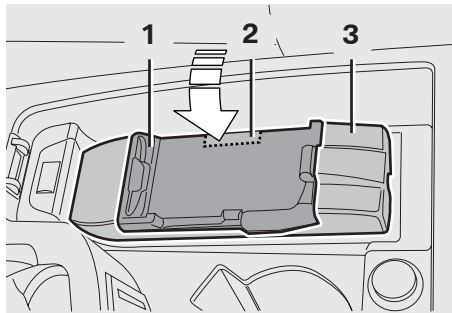

091 0136 Z

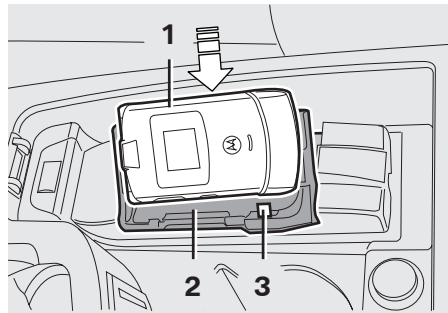

091 0138 Z

- Press on the phone compartment (1) of the Original BMW Snap-In adapter (3) in the marked area (2) to release it.

! To avoid damaging the phone (1) or connecting plug (3), note the correct position to the connecting plug when inserting the mobile phone (1). Avoid using force. ◀

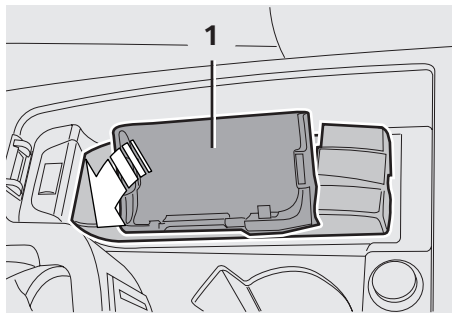

091 0137 Z

- Slide the mobile phone (1) to the side into the phone compartment (2).

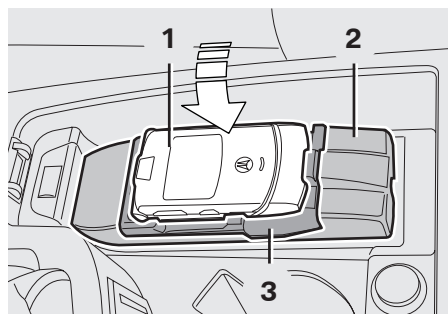

091 0139 Z

The phone compartment (1) is released and swings upwards.

- Press on the right outside edge of the mobile phone (1) to swing the phone compartment (3) downwards and to secure it in the Original BMW Snap-In adapter (2).

The mobile phone (1) is inserted.

Remove the mobile phone from the Original BMW Snap-In adapter

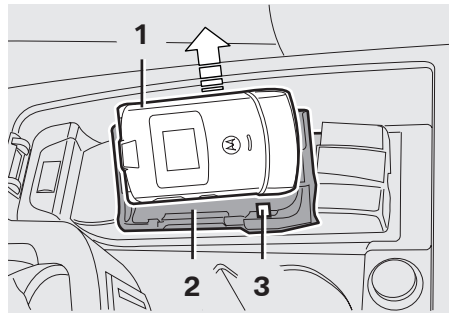
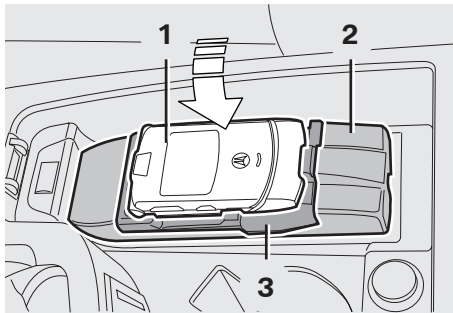

EN

- Press on the right outside edge of the mobile phone (1) to release the phone compartment (3) in the Original BMW Snap-In adapter (2).

! To avoid damaging the phone (1) or connecting plug (3), note the correct position to the connecting plug when removing the mobile phone (1). Avoid using force. ◀

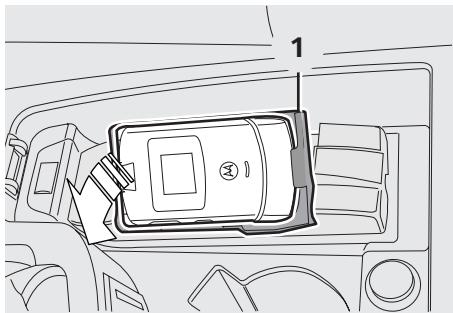

Slide the mobile phone (1) to the side out of the phone compartment (2).

The mobile phone (1) is removed.

The phone compartment (1) is released and swings upwards.

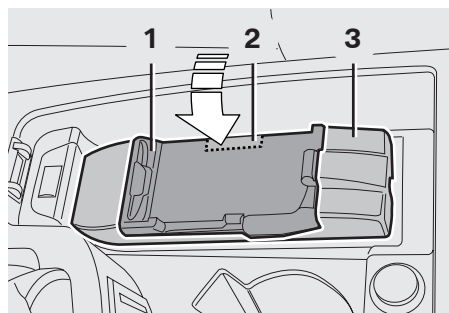

Press on the phone compartment (1) in the marked area (2) to swing it downwards and to release it in the Original BMW Snap-In adapter (3).



Registration of the mobile phone for cars without iDrive

For the following cars

- 1 Series
- 3 Series Saloon built after 12/04
- 3 Series Touring built after 09/05
- 3 Series Coupé built after 08/06

 To register your mobile phone, please select an arbitrary 1-16-digit number as a Bluetooth passkey. This passkey helps your car's Bluetooth hands-free kit communicate with your Bluetooth mobile phone. For security reasons, BMW recommends that you use a multi-digit code (minimum 4 digits) for the Bluetooth pairing and not a trivial number sequence (e.g. "0000" or "1234"). The passkey is no longer needed after registration. ◀

Prepare car for pairing

- Switch on the ignition.
- Press the  key on the car radio.
- Press the  key on the car radio.
- If Bluetooth has not yet been activated in the car, confirm the query **>Switch on for BT telephony!<** by pressing the  key on the car radio.

The following appears on the car radio:
>Search for paired devices<.

- Press the  key on the car radio.











The message on the car radio reads
>BT devices - -<.

- Press the  key on the car radio.



The following appears on the car radio:
>BT devices connectable ...<.

The car is then ready for the pairing.

Prepare mobile phone for pairing

- Switch on the mobile phone and hold the passkey at the ready.
- Press the centre key  on the mobile phone to select the **>Menu<**.
- Use the cursor keys  on the mobile phone to select **>Settings<** and press the centre key  .
- Use the cursor keys  on the mobile phone to select **>Connection<** and press the centre key  .
- Use the cursor keys  on the mobile phone to select **>Bluetooth Link<**  and press the centre key  .
- Use the cursor keys  on the mobile phone to select **>Handsfree<** and press the centre key  .

On the mobile phone appears **>Bluetooth power is off. Temporarily switch on?<**.

- Press the left  key.
- Use the cursor keys  on the mobile phone to select **>Look for devices<** and press the centre key  .

After a successful search, the car appears on the mobile phone with a 5-digit number
>BMWxxxxx<.

The mobile phone is then ready for the pairing.



To pair the mobile phone

- Press the centre key  on the mobile phone.

The message on the phone reads
>Searching... BMWxxxx<.
 The message on the car radio reads
>Ext. device ready<.

- Press the  key on the car radio.

The message on the car radio reads
>Passkey<.

 A maximum of 30 seconds is provided to enter the passkey on the mobile phone and the car. 

Passkey entry in the car



- Using the number keys on the car radio, enter an arbitrary 1-16-digit passkey.
- Press the right-hand knob  on the car radio.

Passkey entry on the mobile phone

The message on the mobile phone reads
>Bond with BMWxxxx?<.

- Press the left  key.

The mobile phone prompts you to enter the passkey:
>Enter the Bluetooth passkey:<

- Using the number keys  on the mobile phone, re-enter the same passkey and press the right  key.

The message on the mobile phone reads
>PIN checked & saved< and **>Connected: BMWxxxx<** in short succession.

The message on the car radio briefly reads
>Pairing succeeded<.

The mobile phone is then paired.

If the mobile phone could not be successfully paired, switch off the ignition and repeat the entire process.

To conclude the registration process

Press the  key on the car radio.

- The device name of your mobile phone, e.g. **>Motorola V3<** is displayed on the car radio.
- Press the left  key on the mobile phone to exit the menu.

The registration of your mobile phone to the car is then complete.

Registration of the mobile phone for cars with iDrive

For the following cars



- 1 Series
- 3 Series Saloon built after 12/04
- 3 Series Touring built after 09/05
- 3 Series Coupé built after 08/06
- 5 Series Saloon built after 03/03
- 5 Series Touring built after 03/04
- 6 Series Coupé
- 6 Series Convertible



 To register your mobile phone, please select an arbitrary 1-16-digit number as a Bluetooth passkey. This passkey helps your car's Bluetooth hands-free kit communicate with your Bluetooth mobile phone. For security reasons, BMW recommends that you use a multi-digit code (minimum 4 digits) for the Bluetooth pairing and not a trivial number sequence (e.g. "0000" or "1234"). The passkey is no longer needed after registration. ◀

Prepare car for pairing



- Switch on the ignition.

The main menu will appear on the Control Display.

- Press the controller  to select menu point >i<.
- Turn the controller  clockwise to select the >Communication interface< menu item and press the controller .

- Turn the controller  clockwise to select the >Settings< menu item and press the controller  to activate >Bluetooth communication<.











The message in the Control Display reads  >Bluetooth communication active<.

- Slide the controller  forwards.
- Turn the controller  anti-clockwise to select the >Telephone< menu item and press the controller .

The message in the Control Display reads >Bluetooth connectable in this menu<.

The car is then ready for the pairing.

Prepare mobile phone for pairing

- Switch on the mobile phone and hold the passkey at the ready.
- Press the centre key  on the mobile phone to select the >Menu<.
- Use the cursor keys  on the mobile phone to select >Settings< and press the centre key .
- Use the cursor keys  on the mobile phone to select >Connection< and press the centre key .
- Use the cursor keys  on the mobile phone to select >Bluetooth Link<  and press the centre key .
- Use the cursor keys  on the mobile phone to select >Handsfree< and press the centre key .

On the mobile phone appears **>Bluetooth power is off. Temporarily switch on?<**.

- Press the left  key.
- Use the cursor keys  on the mobile phone to select **>Look for devices<** and press the centre key  .

After a successful search, the car appears on the mobile phone with a 5-digit number **>BMWxxxxx<**.

The mobile phone is then ready for the pairing.

To pair the mobile phone



- Press the centre key  on the mobile phone.

The message on the phone reads **>Searching... BMW xxxxx<**.



 A maximum of 30 seconds is provided to enter the passkey on the mobile phone and the car. ◀

Passkey entry in the car

The message in the Control Display reads **>External device knocking<**.

- Turn the controller  clockwise to select the **>Add device<** menu item and press the controller  .

The message in the Control Display reads **>Enter passkey<**.

- Enter an arbitrary 1-16-digit passkey using the controller.
- Slide the controller  downward to select the **>Confirm passkey<** menu item and press the controller  .



Passkey entry on the mobile phone

The message on the mobile phone reads **>Bond with BMWxxxxx?<**.

- Press the left  key.

The mobile phone prompts you to enter the passkey:

>Enter the Bluetooth passkey:<

- Using the number keys  on the mobile phone, re-enter the same passkey and press the right  key.



The message on the mobile phone reads **>PIN checked & saved<** and **>Connected: BMWxxxxx<** in short succession.

The device name of your mobile phone, e.g. **>Motorola V3<** is displayed on the Control Display.

The mobile phone is then paired.

If the mobile phone could not be successfully paired, switch off the ignition and quickly repeat the entire process.

To conclude the registration process

- Press the menu key  under the controller twice.
- Press the left  key on the mobile phone to exit the menu.

The registration of your mobile phone to the car is then complete.

Registration of the mobile phone for 7 Series cars built after 09/05









A 4-digit passkey is required for the pairing operation.

The passkey can be taken from the code card included with your car's documents. ◀

Prepare car for pairing

- Switch on the ignition.



The main menu will appear on the Control Display.



- Slide the controller  downward to the left to select the **>Settings<** menu item.
- Turn the controller  clockwise to select the **>Telephone<** menu item and press the controller .
- Turn the controller  clockwise to select the **>Bluetooth<** menu item and press the controller  to switch **>Bluetooth<** on.
- Turn the controller  clockwise to select the **>Pairing<** menu item and press the controller .

>Pairing...< appears in the upper indicator bar of the Control Display.

The car is then ready for the pairing.

Prepare mobile phone for pairing



- Switch on the mobile phone and hold the passkey at the ready.
- Press the centre key  on the mobile phone to select the **>Menu<**.
- Use the cursor keys  on the mobile phone to select **>Settings<** and press the centre key .

- Use the cursor keys  on the mobile phone to select **>Connection<** and press the centre key .

- Use the cursor keys  on the mobile phone to select **>Bluetooth Link<**  and press the centre key .

- Use the cursor keys  on the mobile phone to select **>Handsfree<** and press the centre key .

The message on the mobile phone reads **>Bluetooth power is off. Temporarily switch on?<**.

- Press the left  key.
- Use the cursor keys  on the mobile phone to select **>Look for devices<** and press the centre key .

After a successful search, the car appears on the mobile phone with a 5-digit number **>BMWxxxxx<**.

The mobile phone is then ready for the pairing.

To pair the mobile phone



- Press the centre key  on the mobile phone.

The message on the mobile phone reads
>**Bond with BMWxxxxx?**<.

- Press the left  key.

The mobile phone prompts you to enter the passkey:

>**Enter the Bluetooth passkey:**<

- Using the number keys  on the mobile phone, enter the 4-digit passkey and press the centre  key.

The message on the mobile phone reads
>**PIN checked & saved**< and >**Connected:
BMWxxxxx**< in short succession.

The device name of your mobile phone, e.g.
>**Motorola V3**< is displayed on the Control Display.

The mobile phone is then paired.

If the mobile phone could not be successfully paired, switch off the ignition and quickly repeat the entire process.

To conclude the registration process

- Press the menu key  under the controller twice.

- Press the left  key on the mobile phone to exit the menu.

The registration of your mobile phone to the car is then complete.