

## Component

**Jumper (Blue) Plug - P/N 84 11 0 018 038**

**Work Around Kit - P/N 84 11 0 018 221**

### Section A: Jumper (Blue) Plug for SES connector

## Procedure

**Section A**

**Section B**

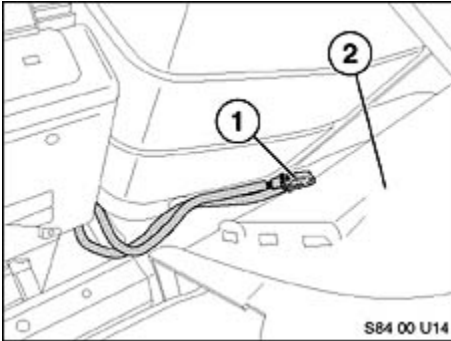

The SES connector X10390 (1) is a blue 26-pin male ELO type connector, and is located in the left rear trunk area behind the wheel well panel (2).

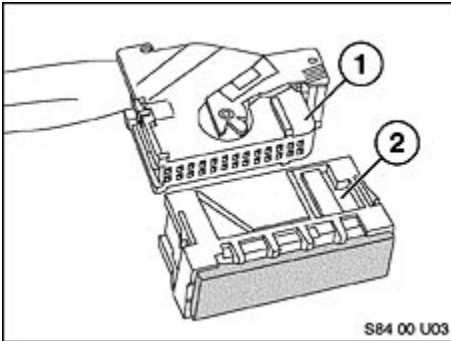

To install the blue Jumper Plug:

1. Insert SES connector (1) into the blue Jumper Plug (2)

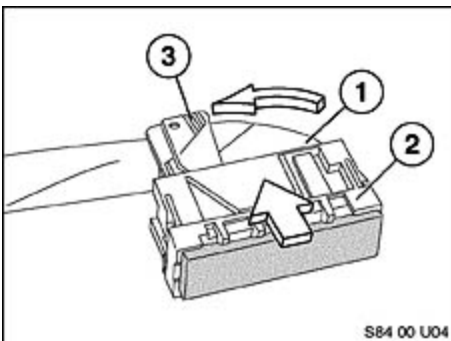

2. Lock Jumper Plug onto SES connector by rotating locking lever (3) into full lock position. Phone wiring harness is capable now of accepting the CPT 7000 digital phone.
3. For the CPT 7000 phone installation procedure, refer to the detailed instruction included in the **"CPT 7000, 750iL Installation Kit"**

## Section B: Work Around Kit (Siemens self-stripping, black connectors) for SES harness

Starting from the SES connector end, peel back and discard approximately 9" of the black harness wrap.

**The following wires must be jumped in the SES harness:**

- Pin 18 to pin 23
- Pin 8 to pin 10
- Pin 9 to pin 11
- Pin 12 to pin 25
- Pin 13 to pin 26

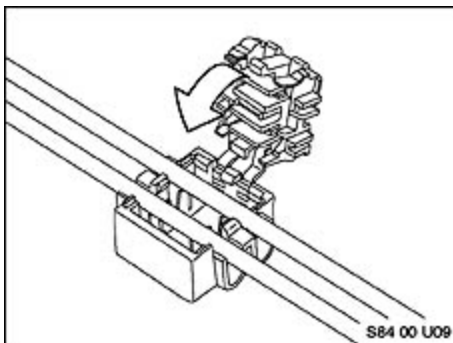

1. Using the Siemens self-stripping connectors from the Work Around Kit, connect (jump) the pairs of wires outline in step 1. Position a pair of wires to be jumped over base of connector. Make sure, each wire is aligned with the guide channels that are part of the connector base.

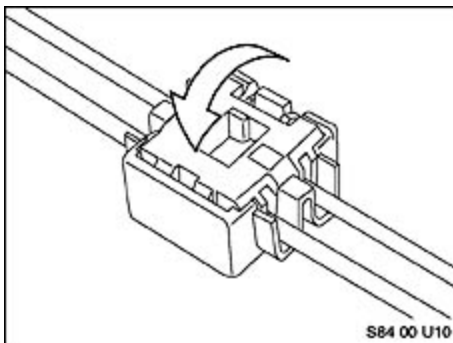

2. Swing the locking cap of the connector over the top of wires. Using a pair of pliers, press down on locking cap until top of the cap is flush with sides of the connector.

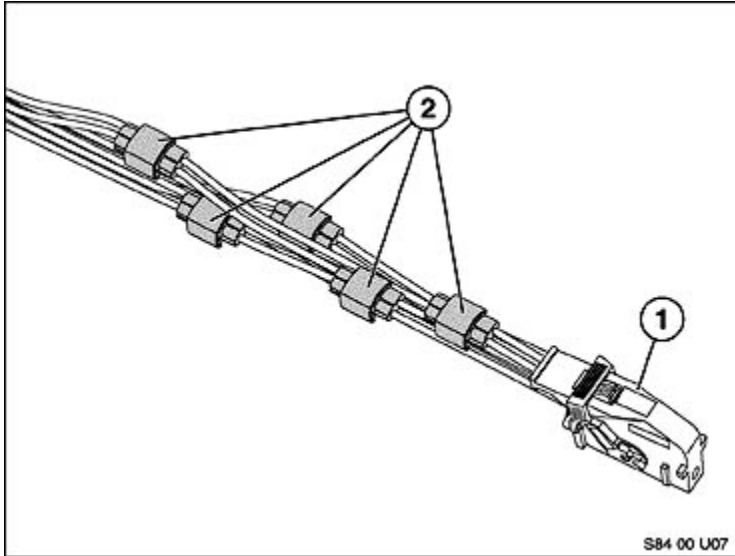

3. Space the connectors evenly along the exposed section of the harness, allowing enough space between connectors to ensure that the pairs of wires are not being pulled or strained.

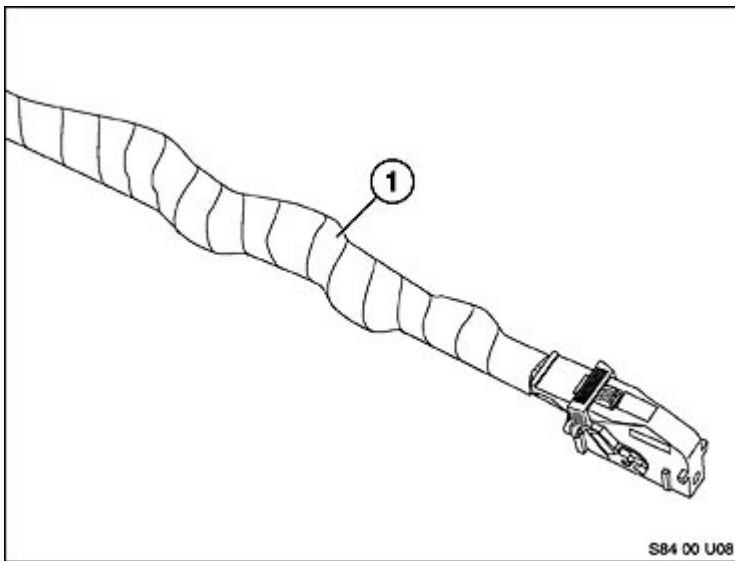

4. Carefully re-wrap (1) harness with a good quality vinyl electrical tape (such as 3M Scotch™ Super 33 Automotive Vinyl Electrical Tape - 3M part number 054007-06133). Vehicle phone harness is now capable of accepting the digital CPT 7000 phone.
5. For the CPT 7000 phone installation procedure, refer to the detailed instruction included in the "**CPT 7000, 750iL Installation Kit**"